

Operation Instruction of 7.2GHz 3W Transmitter (VTX)

I. Product Appearance

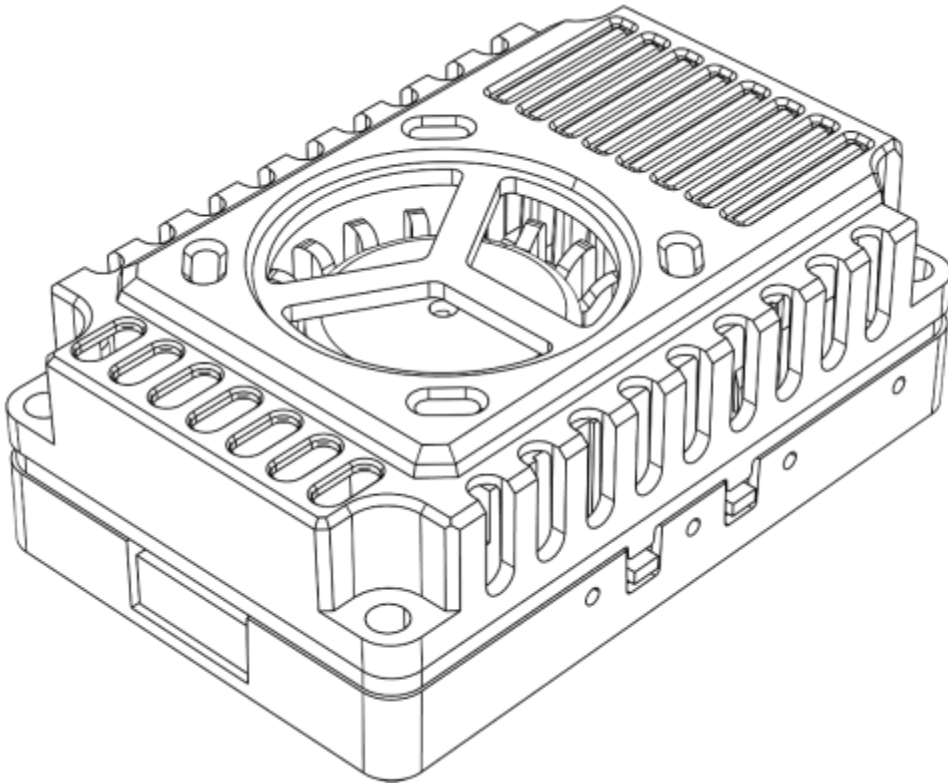

II. Product Dimension

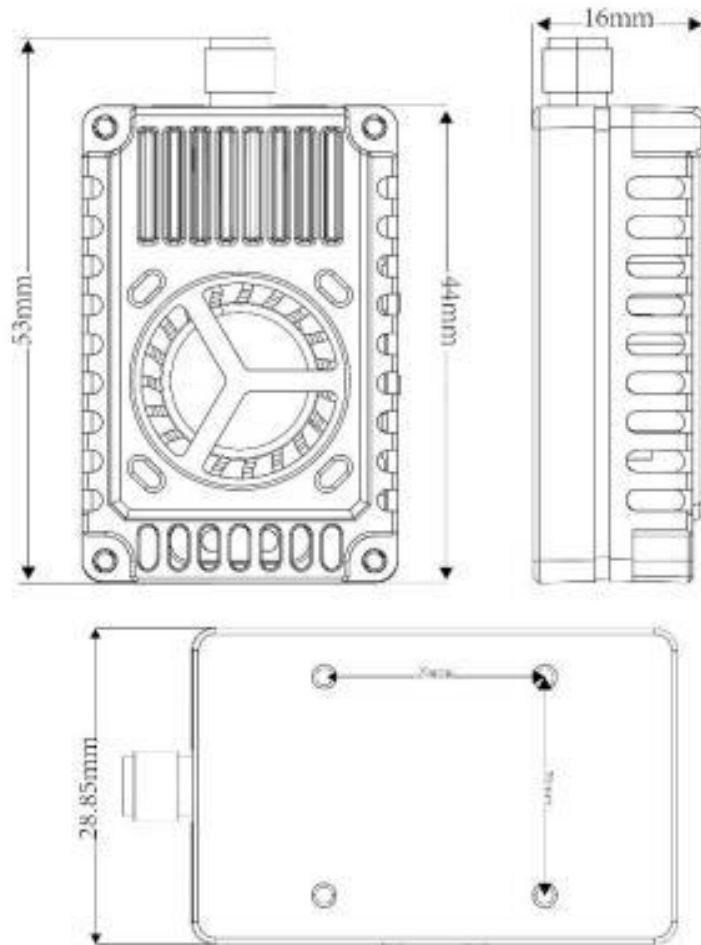

III. Specifications

1. 7.2GHz 64CH: 6110MHz-7210MHz;
2. Max power: 3W (25mW, 1000mW, 3000mW, adjustable);
3. Input voltage: DC 7V-36V, supporting 2-8S battery input
4. Antenna connector: SMA Mother seat inner hole
5. Smart audio: IRC Tramp
6. Heat-dissipating method: aluminum alloy shell, heat sink&fan
7. Hole spacing: 20mm*20mm/ø2mm
8. Dimension: 53mm*28.85mm*16mm
9. Weight: 25.85g

IV. Function Introduction

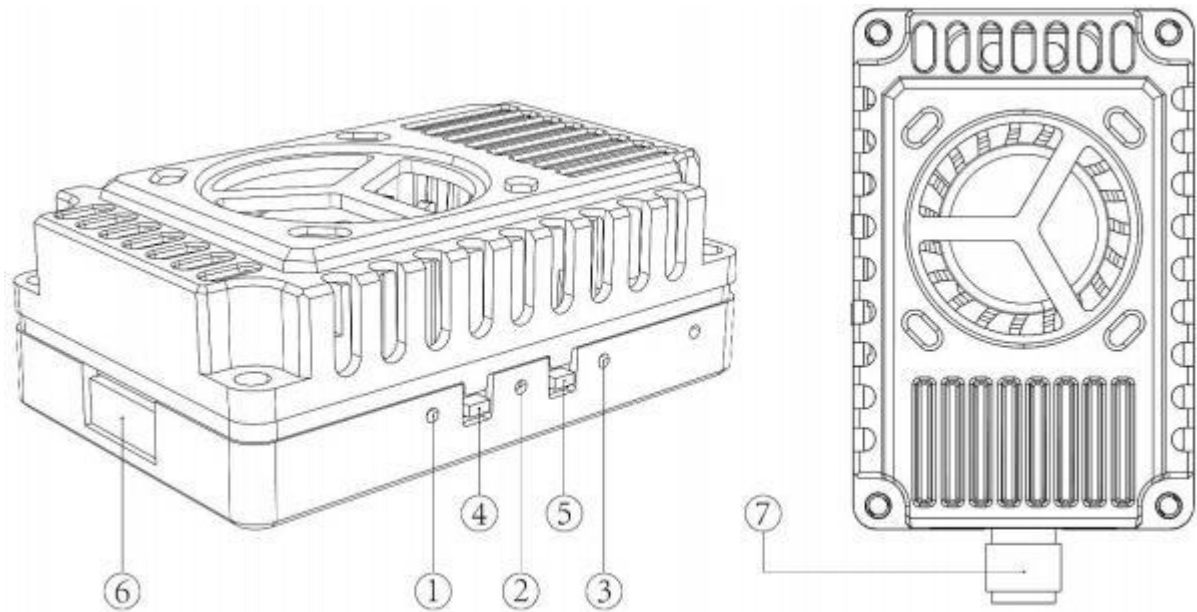

1. Channel indicator: Red LED
2. Band indicator: Blue LED
3. Power indicator: Green LED
4. Band & Channel changer button
5. Power changer button
6. 1.0 6P Power connector
7. SMA Mother seat inner hole

V. Control Method and LED Indicator

1. Button (4) is the frequency point and frequency band switch button; each short press of button (4) switches to the next frequency point, and the corresponding red LED flashes, in order: frequency points 1, 2, 3, 4, 5, 6, 7, and 8. This operation can be repeated in a loop; see the figure below for details:

Short press button ④ to switch channel									
Red LED	CH1	CH2	CH3	CH4	CH5	CH6	CH7	CH8	
	Flash once	Flash twice	Flash for 3 times	Flash for 4 times	Flash for 5 times	Flash for 6 times	Flash for 7 times	Flash for 8 times	

2. Long press button ④ to switch frequency bands. Long press for 5 seconds and the corresponding blue LED will flash, in order: frequency groups A, B, E, F, R, P, H, U. This operation can be repeated; see the figure below for details:

Long press button ④ to switch bands								
Blue LED	Flash once	Flash twice	Flash for 3 times	Flash for 4 times	Flash for 5 times	Flash for 6 times	Flash for 7 times	Flash for 8 times
	A	B	E	F	R	P	H	U

3. Button ⑤ is the power adjustment button. Each short press switches the power by one level, cycling between the three levels of 25mW, 1000mW, and 3000mW. The green LED is the power indicator light, with the following states as shown in the figure below: 25mW flashes once, 1000mW flashes twice, and 3000mW flashes three times. Holding the button for 3 seconds enters pit mode, with the green light staying on. See the figure below for details:

Short press button ⑤ Power switch				
Green LED	Pit Mode	25mw	1000mw	3000mw
	Everlasting brightness	Flashes 1 time	Flashes twice	Flashes three times

Note: This image transmission device has a temperature protection function. When the temperature of the image transmission device exceeds 100° C, the transmission power of the image transmission device will be reduced by one level. If the temperature remains above 100° C, the transmission power will be reduced by another level until it reaches the lowest power level (25mW). At this point, the temperature of the image transmission

device will decrease. When the temperature drops to 95° C, the transmission power will return to the originally set power level.

VI. Frequency Table

Frequency Table								
Channel Band	CH1	CH2	CH3	CH4	CH5	CH6	CH7	CH8
BAND A	6110	6130	6150	6170	6190	6210	6230	6250
BAND B	6270	6290	6310	6330	6350	6370	6390	6410
BAND E	6430	6450	6470	6490	6510	6530	6550	6570
BAND F	6590	6610	6630	6650	6670	6690	6710	6730
BAND R	6750	6770	6790	6810	6830	6850	6870	6890
BAND P	6910	6930	6950	6970	6990	7010	7030	7050
BAND H	7070	7090	7110	7130	7150	7170	7190	7210
BAND U	6115	6265	6425	6585	6745	6905	7065	7185

VII. Illustrate of 6P 1.0 Wiring

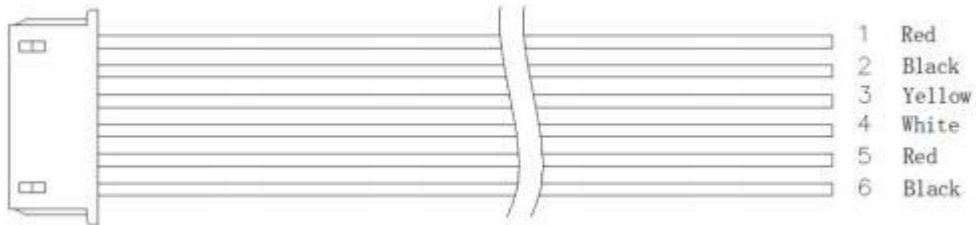

Wiring Table:

NO	1	2	3	4	5	6
FUN	7-36V	GND	Video	IRC	5VOut	GND
Color	Red	Black	Yellow	White	Red	Black

VIII. Notice for Use:

1. The VTX must be installed with space to ensure that the air convection around the module to ensure that the module heat dissipation; otherwise, the module overheating protection start, reduce the power to transmit, or even shut down the power to transmit.
2. It is recommended that before turning on the power, to ensure that the correct voltage range, positive and negative poles are correct, so as not to burn components.
3. It is recommended that before turning on the power, make sure that the RF RF output has been installed antenna, which can extend the life of the module.
4. Please read the instruction manual before use, so that you can correctly wire and extend the module service life.